

ASSEMBLY INSTRUCTIONS:

Product Code : GC10 / GC18 / GC20

Product Name: GO Swing Door Cupboards

TIME REQUIRED:

35 minutes

TOOLS REQUIRED:

Pop Rivet Gun

*Tools are not included.

SKILL REQUIRED:

Easy  Hard

The Assembly Skill Rating is a 5-point system that shows the degree of effort needed in assembling a specific product. With 1 being easy for the average person and 5 requiring an expert. For most products, two persons are recommended.

NOTE

- As this is a commercial product, some intermediate skills may be required.
 - No pre-drill holes or markings are provided on our table or desk tops.
 - Please check you have all hardware before assembling.
- If you are missing any hardware, please contact your Rapidline reseller. Please ensure you have the name of the item, required hardware part and quantity.
 - Please retain your receipt as proof of purchase to validate your warranty.
- Assemble on a clean, flat, smooth surface such as a rug or carpet to avoid parts from being scratched.
- Remove all wrapping materials, including staples and packing straps before you start to assemble
 - Keep all hardware parts out of reach of children.

CAUTION

- Heavy product. Do not attempt to lift or move without help
- Do not tighten screws and bolts until completely assembled.
- Do not use this product unless all bolts and screws are firmly secured and tightened.

WARNING

- If parts are missing, broken, damaged or worn stop using the product until all repairs are made.
- Failure to follow these warnings could result in serious injury.

GC10N/ GC18N AND GC20N ASSEMBLY INSTRUCTIONS

PART LIST

Part No	Component	Quantity
01	RH Back	01
02	LH Back	01
03	RH SIDE	01
04	LH SIDE	01
05	Bottom Channel	01
06	Bottom Front	01
07	Bottom Tray	01
08	Top	01
09	RH DOOR	01
10	LH DOOR	01
11	Top Hinge Pin (Straight)	02
12	Bottom Hinge Pin (with head)	02
13	Shelf Clip	08,12,16
14	Adjustable Shelves	2,3,4
15	Door Stoppers	04
16	Rivets 4x8	35,40,42
17	Rivets 4x8 STEEL	02

The Qty of Shelf clips and Shelves is given for GC10N, GC18N and GC20N respectively

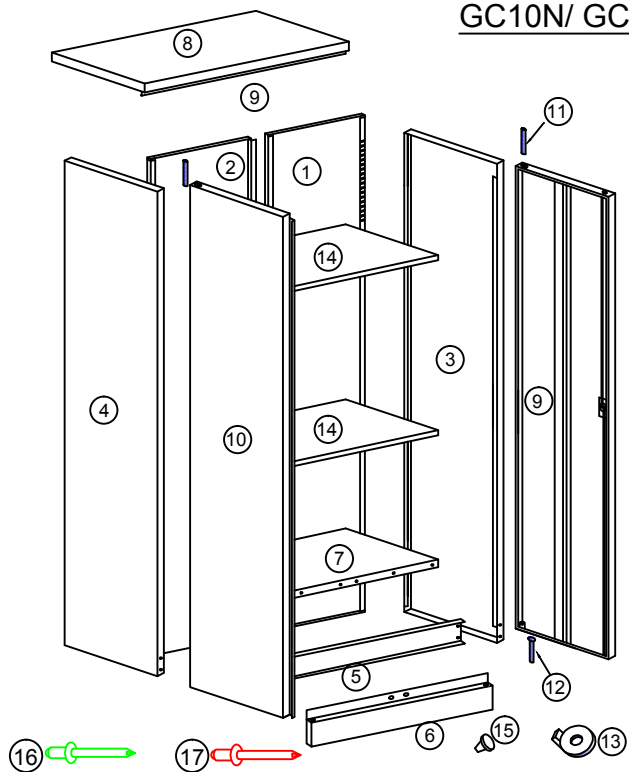

STEP-1

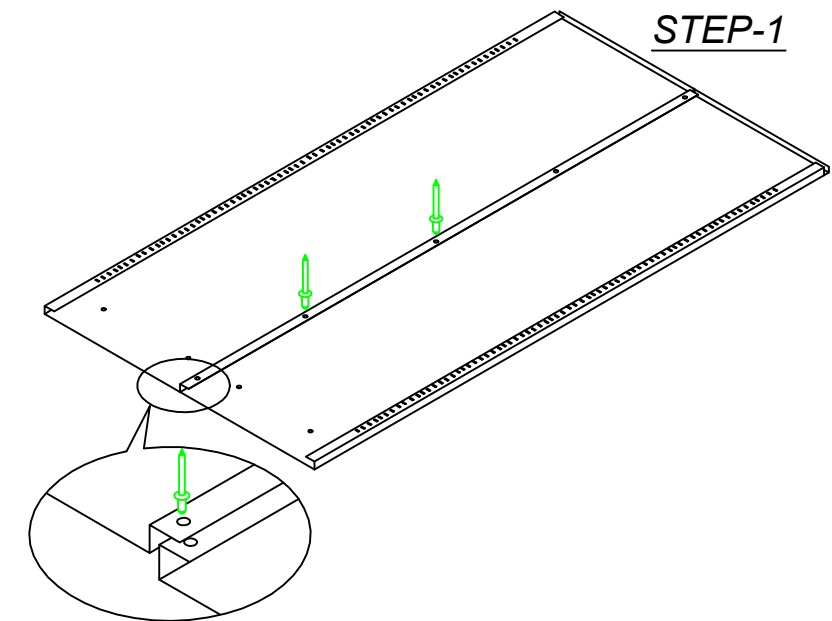

1. Place the RH back on the assembly table.
2. Place the LH back on the Right hand back fold as shown and rivet.

STEP-2

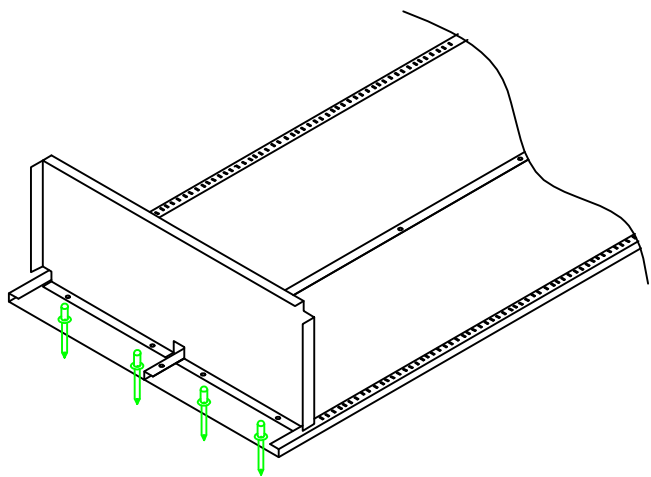

Fix the Bottom tray as shown and Rivet from outside.

STEP-3

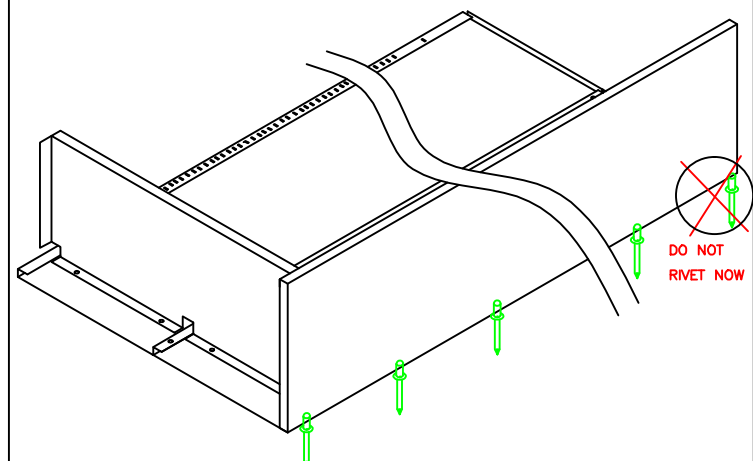

Assemble RH Side with RH back as shown and rivet from outside. **DO NOT** Rivet the topmost rivet which will be riveted along with TOP. Similarly Assemble LH Side.

STEP-4

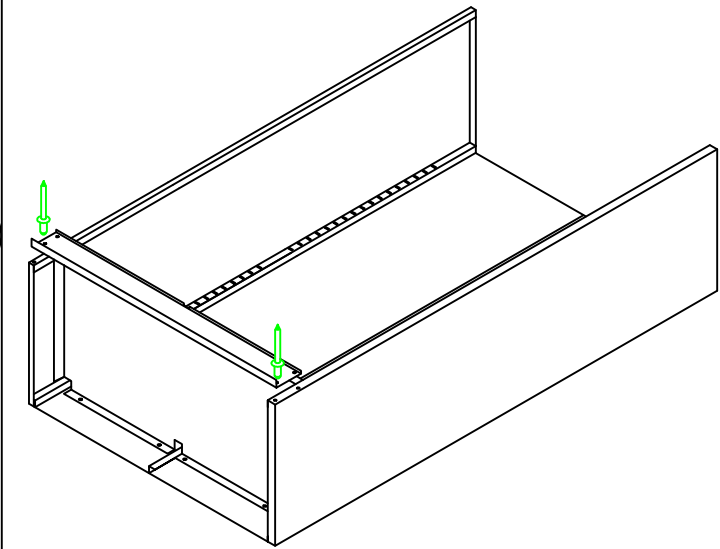

Assemble the Bottom channel as shown and Rivet with sides.

STEP-5

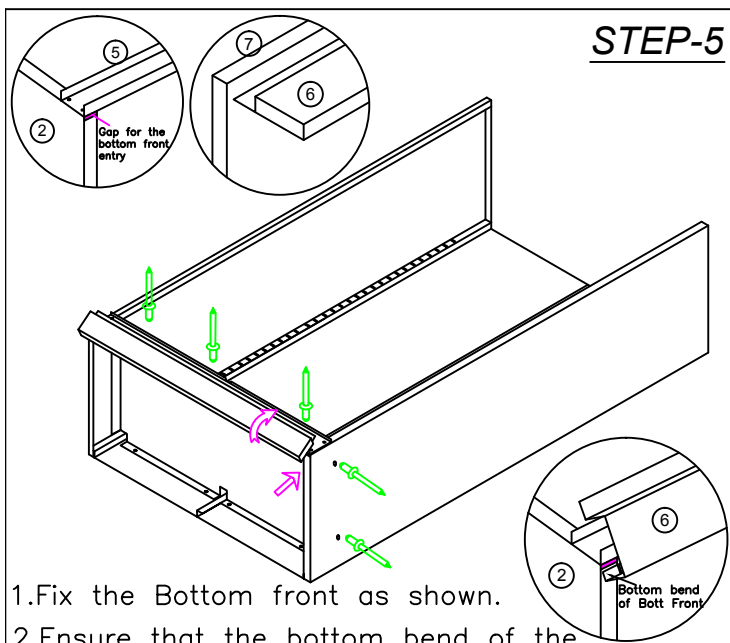

1. Fix the Bottom front as shown.
2. Ensure that the bottom bend of the bottom front will engage with the sides and the bottom channel as shown in the enlarged view.
3. Check that the Bottom tray comes above the bottom front and Rivet together.

STEP-6

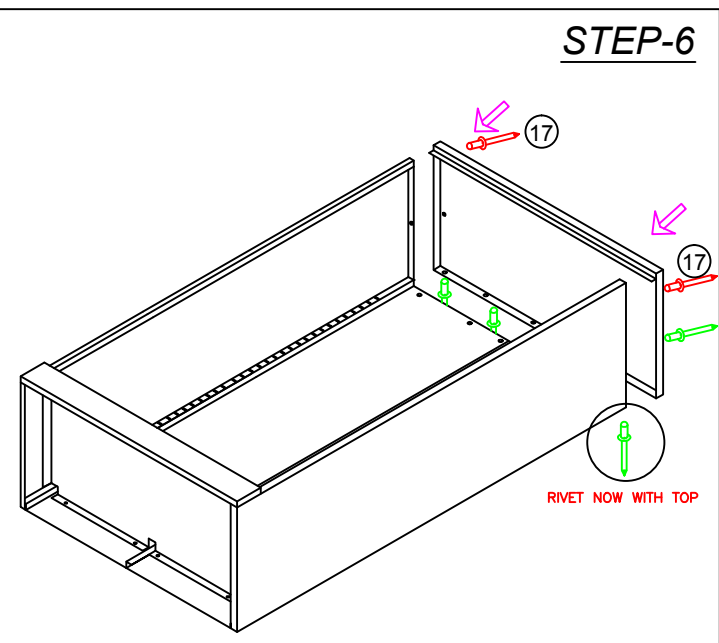

Assemble the top and rivet with Backs and sides as shown. Now the carcass is ready. please erect the carcass for doors fixing.

STEP-7

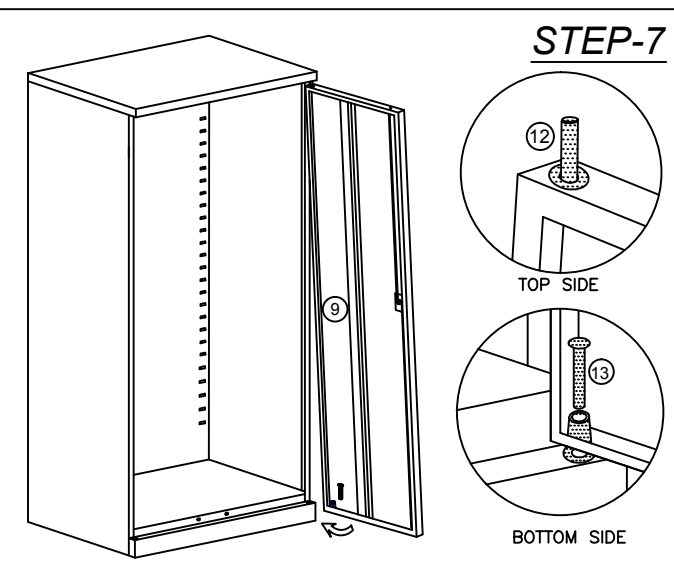

1. Insert the Top Hinge pin in the top Hinge Bush and fix the Door as shown in the drawing.
2. Position the Door on the Bottom front and then insert the bottom Hinge pin from top as shown.
3. Similarly fix the LH Door.

STEP-8

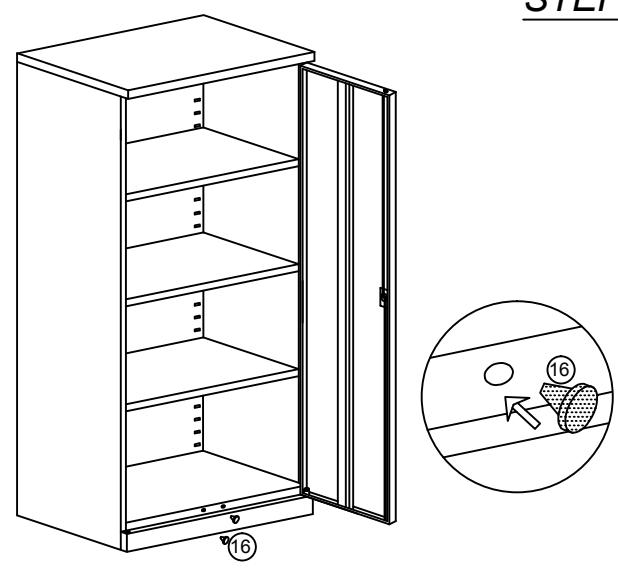

Fix the Door Stoppers on the Top and Bottom Tray holes as shown.

STEP-9

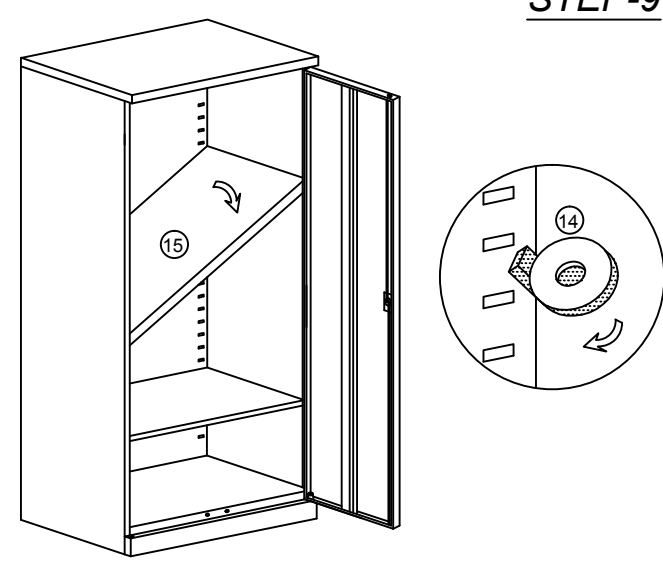

1. Fix the Shelf Clips at the desired level as shown. Ensure that all 4 Clips are at the same height
2. Fix the Shelf on the Shelf clips as shown

STEP-10

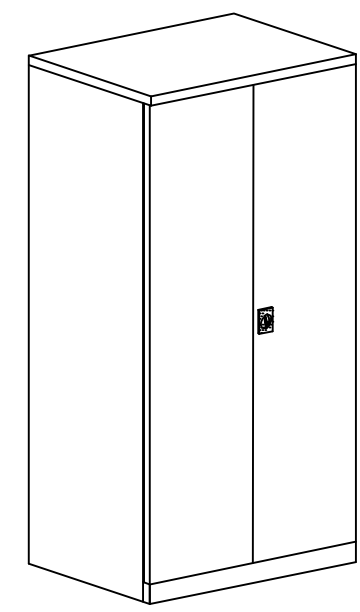

Now the cupboard is ready for use.